



SERVICE BULLETIN 19-08-26

Date Released:	January 27, 2020 January 31, 2020 – applicability clarifications added
Date Effective:	January 27, 2020
Subject:	WD-1201 Nose gear leg replacement
Affected Models:	All RV-12/RV-12iS with finish kits shipped before 06-10-19
Affected Serial Numbers:	SLSA RV-12/RV-12iS aircraft with serial numbers 12080 and earlier
Required Action:	Replace WD-1201 with WD-1201-1-RTR Nose Gear
Time of Compliance:	At or before the next annual condition inspection
Labor Required / SLSA Warranty Allowance:	7.0 hours
Level of Certification:	S-LSA: LSA Repairman - Maintenance or A&P E-LSA/EAB: Aircraft Owner

Synopsis: An RV-12 training aircraft with more than 1700 hours of accumulated flight time recently experienced a nose gear fatigue failure. This is the only reported instance; no other fatigue-related nose gear failures have been reported. The failure occurred in the nose gear leg at the point where the leg tube meets the lower attachment bracket, and was caused by a fatigue crack that propagated across the tube. The crack occurred at a location that is not visually inspectable. It is, therefore, strongly recommended that owners of RV-12/RV-12iS aircraft with the original style nose gear leg (WD-1201) replace that part with the available updated, reinforced leg - part number WD-1201-1.

NOTE: Only original WD-1201 legs, which were shipped prior to June 10th, 2019, are affected by this service bulletin. If you have received a WD-1201-1 gear leg since that time either with your kit or as a backorder item, it is not affected.

NOTE: In addition, only if your RV-12 or RV-12iS is currently under construction, and you received your finishing kit prior to June 10, 2019, and you have not yet completed the following steps in your plans, please contact Van's Aircraft to order a replacement gear leg rather than ordering the retrofit kits listed below.

- RV-12iS: Section 46iS-05, Steps 1-7
- Original RV-12: Section 46-08, Steps 1-3

If you have already completed those steps, please follow the instructions that appear starting on the next page.

Materials Required:

The following materials are required to complete the steps necessary to achieve compliance with this Service Bulletin:

- a. For RV-12/12iS Finish Kits shipped prior to June 6th, 2019 purchase the applicable service bulletin kit from Van's Aircraft:

For RV-12	Part no.	SB 19-08-26
For RV-12iS	Part no.	SB 19-08-26iS

- b. The following tools are required:

- 18 inch long Ø1/8 drill bit (Van's Part no. TOOL-00040) **
- 18 inch long Ø1/4 drill bit (Van's Part no. TOOL-00041) **
- 18 inch long Ø3/8 drill bit (Van's Part no. TOOL-00042) **
- #30 drill bit
- 8-32 tap (if nose leg fairing is installed)
- Drilling lubricant (e.g. Boelube)

** The three drill bits listed above may also be purchased as a set from Van's Aircraft. Order Part no. TOOL-00038 to obtain the complete set of three drill bits.

Method of Compliance:

Step 1: Remove the cowling.

Step 2: If applicable, remove the nose wheel fairing and nose leg fairing.

Step 3 (RV-12 Only): Remove the F-1230 Tunnel Cover depicted on KAI Page 33-03.

Step 4: Remove the AN3 bolt securing the F-01285 Cowl Bottom Close-out from the bottom bracket of the WD-1201 Nose Gear Assembly.

- For RV-12, refer to KAI Page 38-09
- For RV-12iS, refer to KAI Page 37iS/U-16

Step 5: Remove the nuts from the two bolts that attach the nose gear assembly and the bottom of the engine mount to the firewall.

- For RV-12, refer to KAI Page 46-08
- For RV-12iS, refer to KAI Page 46iS-05 or 46U-10

CAUTION: The following steps require hoisting the engine. To prevent the aircraft from unintentionally tipping too far back while the engine is hoisted, chock the wheels and place a padded, approximately 28 inch high saw horse under the third bulkhead from the aft end of the tailcone. Before and during hoisting, ensure that there is adequate slack in hoses, cables, and wires to allow the engine and engine mount to move forward approximately two inches.

Step 6 (RV-12 Only): Remove the AN3 bolt from the cushion clamp that secures the FF-1208A Radiator Hose to the front of the nose gear assembly.

Step 7: With straps wrapped around the intake manifolds (see Figure 1), hoist the engine just enough to unload the two engine mount/nose landing gear bolts, then remove the bolts.

Step 8: Hoist the engine until the tailcone contacts the sawhorse at the third bulkhead. Then, continue to hoist until a gap forms between the bottom of the engine mount and the nose gear assembly bracket. The gap should be just large enough to allow removal of the bottom isolators. Remove the two bottom isolators.

- For RV-12, refer to KAI Page 46-08
- For RV-12iS, refer to KAI Page 46iS-05 or 46U-10

Step 9: Unbolt and remove the nose gear assembly from the fuselage.

Step 10: Remove the nose wheel/fork assembly from the nose gear leg and reinstall on the new WD-1201-1-RTR Nose Gear Leg.

- For RV-12, refer to KAI Page 35-08
- For RV-12iS, refer to KAI Page 35iS/U-09

NOTE: Do not set the 18-20 pound nose fork break-out force yet. Wait until Step 23.

Step 11: Temporarily attach the WD-1201-1 Nose Gear Leg to the fuselage using the four bolts shown in Figure 2.



FIGURE 1: ENGINE HOISTING

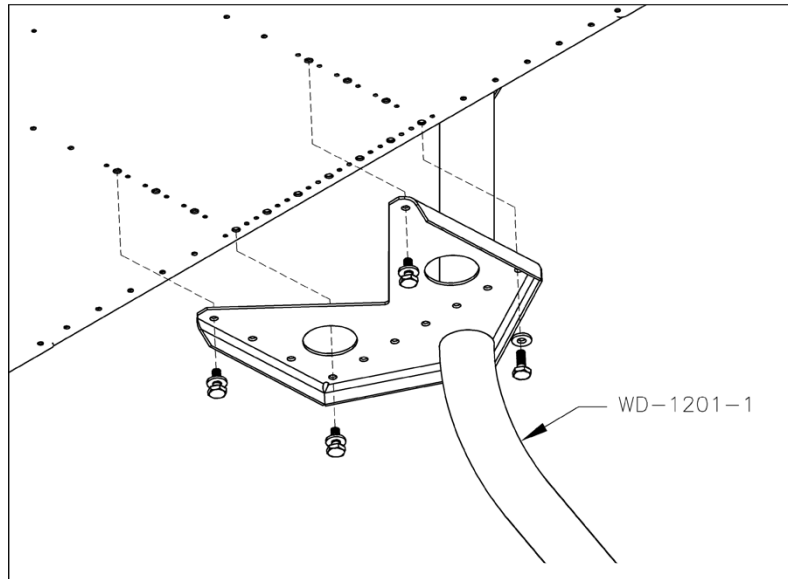

FIGURE 2: TEMPORARY ATTACHMENT OF NOSE GEAR ASSEMBLY

Step 12: Insert a 3/4 to 1 inch wood spacer between the bottom of the engine mount and the top bracket of the nose landing gear (to compensate for the removed engine isolators), then lower the engine until the nose wheel contacts the ground and the load on the nose gear firmly presses the top bracket of the nose gear against the firewall.

NOTE: The following steps require drilling the heat-treated nose gear leg. When drilling, use plenty of lubricant (e.g. Boelube) and keep the drill speed low. To keep the drill clear of the tunnel sides, use extended length drill bits.

Step 13: From the back side of the firewall, insert the reduced diameter end of the VA-268 Drill Bushing into the $\text{\O}.$ 375 [9.5 mm] hole in the right WD-1204 Engine Mount Bracket.

- For RV-12, refer to KAI Page 46-08
- For RV-12iS, refer to KAI Page 22iS/U-01)

Hold the drill bushing against the engine mount bracket. Then, while keeping the drill bit perpendicular to the firewall, match-drill .125 the nose gear leg.

Step 14: Remove the VA-268 and insert the VA-269 Drill Bushing. Drill up the .125 hole to .250.

Step 15: Remove the VA-269 Drill Bushing, then, using the firewall bracket as a guide, final-drill .375 the .250 hole in the nose gear leg.

Step 16: Insert an AN6 bolt into the hole to keep the nose gear assembly and firewall aligned while drilling the left engine mount bracket.

Step 17: Repeat Steps 13-15 for the hole in the left engine mount bracket.

Step 18: Remove the nose gear leg, deburr the holes and clear away all drill shavings.

Step 19: Bolt the bottom bracket of the nose gear leg to the fuselage. RV-12, see KAI Page 35-08; RV-12iS, see KAI Page 35iS/U-09. (Do not install the bolt used to attach the F-01285 Cowl Bottom Close-out.)

Step 20: Reinstall the bottom two engine mount isolators, then bolt the bottom of the engine mount and the nose gear leg to the firewall.

- For RV-12, refer to KAI Page 46-08
- For RV-12iS, refer to KAI Page 46iS-05 or 46U-10

Step 21: Reinstall the F-01285 Cowl Bottom Close-out.

- For RV-12, refer to KAI Page 38-09
- For RV-12iS, refer to KAI Page 37iS/U-16

Step 22 (RV-12 Only): Secure the FF-1208A Radiator Hose to the front of the nose gear leg using the hardware shown in Figure 3.

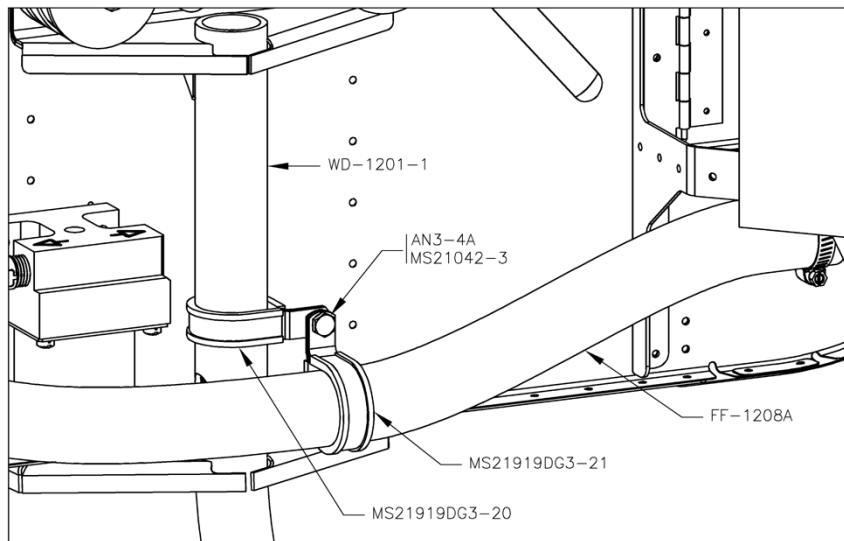

FIGURE 3: SECURING THE FF-1208A RADIATOR HOSE (RV-12 ONLY)

Step 23: Set the nose fork break-out force to the stated 18-20 pounds, then drill the nose gear for the cotter pin and install.

- For RV-12, refer to KAI Page 35-08
- For RV-12iS, refer to KAI Page 35iS/U-09

Step 24: If applicable, reinstall the U-00007 Nose Leg Fairing as follows:

- For RV-12, refer to KAI Page 36A-12
 - For RV-12iS, refer to KAI Page 36iS/U-14
- a) Slip the nose leg fairing in place over the nose gear leg and insert the hinge pin to close the trailing edge.

- b) Attach plumb lines to the upper portion of the nose leg fairing as shown in Section A-A, and align the nose leg fairing so that it is centered between the plumb lines.
- c) Clamp the upper portion of the nose leg fairing in place when satisfied with the position.
- d) Center-punch, then drill #30 holes into both sides of the nose gear leg centered on the existing holes in the nose leg fairing. Be careful to prevent the hole from “wandering” off center while drilling.
- e) Tap 8-32 the two holes drilled in the nose leg assembly, then secure the nose leg fairing with the original screws.

Step 25: If applicable, reinstall the nose wheel fairing and ensure clearance with the nose leg fairing through full rotation of the nose fork.

Step 26: Reinstall any component that might have been removed to gain access.

Step 27: Reinstall the cowling.

Step 28: Make a logbook entry indicating compliance with SB 19-08-26. Place a copy of this notification in the back of the maintenance manual for your aircraft. Note the addition of this notification to the bottom of the Maintenance Manual table of contents.